

# WIR TX-9 DC, WIR TX-90 DC

Infrared Emitter and Transmitter

Installation Guide & User Manual

Optional Receiver Models WIR RX22-4, WIR RX18  
Optional Charger Models CHG 518, CHG 3512



## Contents

---

System Overview .....	3
Determine Coverage Area.....	4
Connect Power .....	6
Power Connection (Universal) .....	6
Connect Audio Source.....	7
Selecting a Carrier Frequency.....	7
Selecting a Channel.....	7
Select the Audio Processing Application Preset.....	8
Adjusting Audio Input Level.....	8
Adjusting Tone .....	8
Using the Optional WIR TX9 DC Slave Emitter for Additional Coverage .....	9
Receiver Safety Information.....	10
Recycling Instructions.....	10
Optional Infrared Receivers.....	11
Optional Chargers .....	12
Troubleshooting .....	13
The WIR TX90 DC “Power On” indicator is not lit .....	13
The WIR TX90 DC channel A or B “On” indicator is not lit .....	13
No sound through receivers .....	13
Sound through the receivers is weak and noisy .....	13
Buzzing or humming noise in sound system .....	13
Specifications - WIR TX90 DC .....	14
Specifications - WIR TX9 DC.....	15
Limited Warranty.....	15

# System Overview

The WIR TX90 DC two channel infrared transmitter combines infrared modulator and emitter technology into a single mountable enclosure - reducing operating cost and eliminating precious rack space.

The WIR TX90 DC features an easy to use configuration preset for Music, Voice, or Hearing Assistance Applications. It operates on dual 2.3/2.8 or 3.3/3.8 MHz selectable frequencies - ideal for high quality audio programs such as music, theater and audio description. The WIR TX90 DC will accept any line level, balanced or unbalanced audio inputs, and includes adjustable tone and volume control. Infrared receivers detect the transmission and convert the light signals back into audio signals. The 2.3-3.8 MHz operating frequencies minimize high efficiency lighting interference. No FCC license or radio approval is required with this equipment. It can be used anywhere in the world.

**NOTE:** This equipment has been tested and found to comply with the limits for a Class A digital device, pursuant to part 15 of the FCC Rules. These limits are designed to provide reasonable protection against harmful interference when the equipment is operated in a commercial environment.

**NOTICE:** A plasma monitor can degrade the audio quality of the Infrared Listening System.

## Typical Two-Channel configuration for the WIR TX90 DC

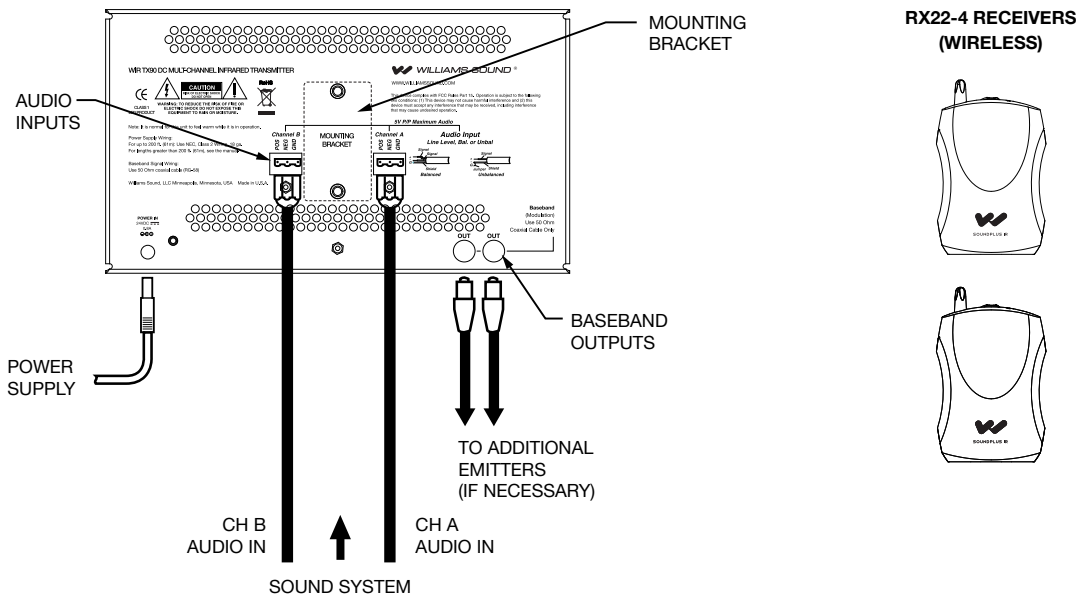

## Determine Coverage Area

Determine the coverage area needed for the seating area. When using the WIR TX90 DC transmitter with the RX22-4 receiver, in single channel mode, the WIR TX90 DC can achieve a coverage area of 30,000 sq. ft. (2,787 sq. m.). In four channel mode, the WIR TX90 DC divides its power among the four signals to achieve a coverage area of 11,000 sq. ft. (1,022 sq. m.).

**NOTE:** The coverage area will vary depending on the sensitivity of the infrared receiver being used. The following diagram illustrates coverage area when using a RX22-4, RX15-2, or RX18 receiver with a single WIR TX90 DC transmitter in single channel mode.

### Maximum range when using the RX22-4, RX15-2, or RX18 Receiver

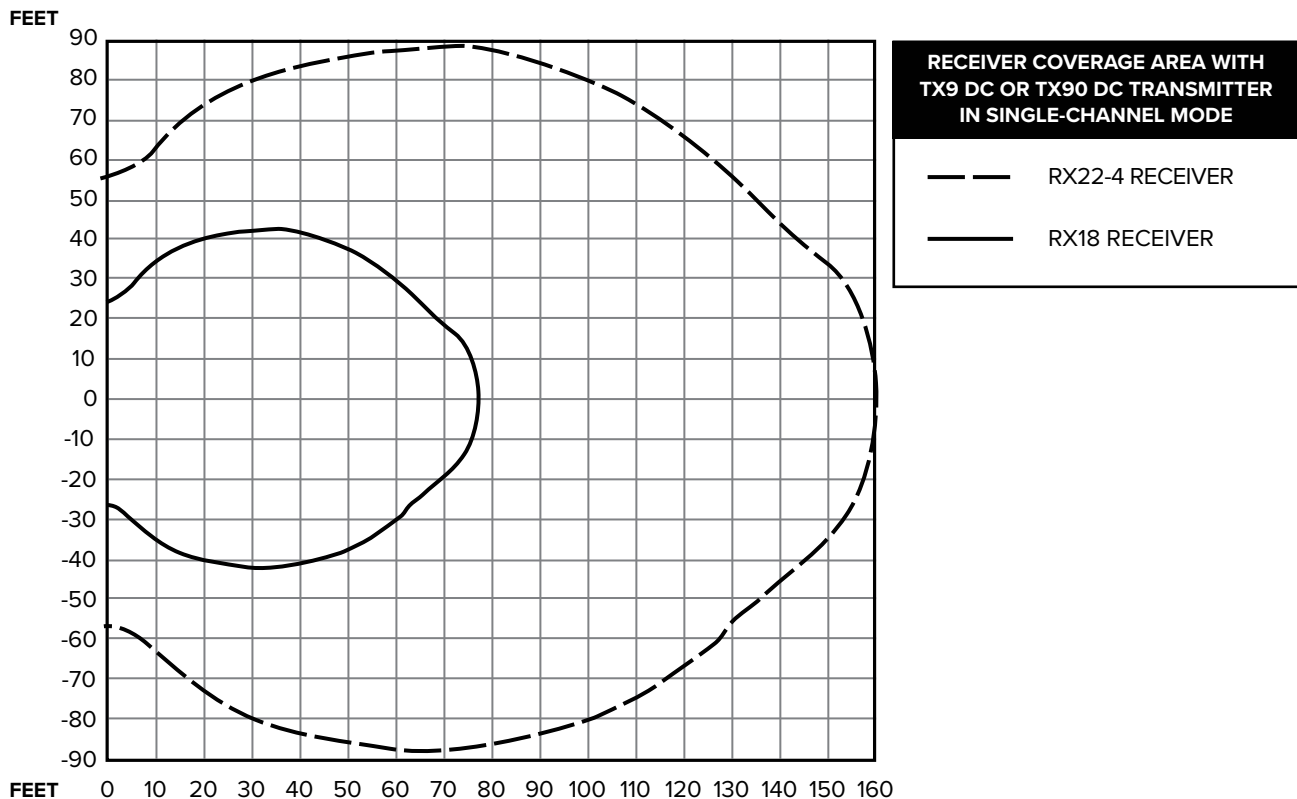

These patterns are the direct radiation pattern. The infrared radiation does not drop to zero outside the illustrated patterns; it decreases. It still may be useable at a greater distance, depending on the receiver sensitivity and the reflective characteristics of the room.

Reflections of the infrared light from walls, ceilings, and floors may change these patterns.

**Important: Remember to point the transmitter towards the listening audience!**

Remember: opaque objects block infrared light. Thus, the transmitter cannot be concealed behind opaque walls, curtains, etc.

**3-Dimensional IR Illumination Pattern**

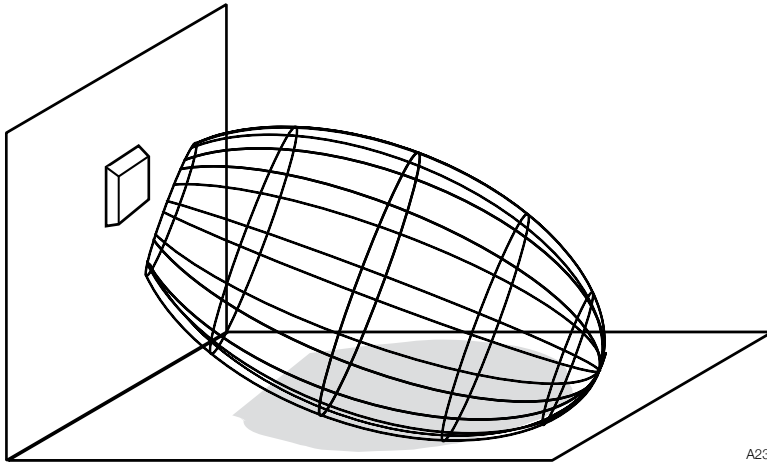

**When pointing the emitter, be sure to keep the long dimension horizontal.**



**CORRECT**

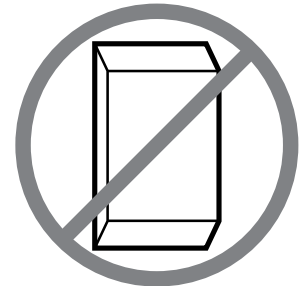

**INCORRECT**

**Overlapping Illumination patterns to cover Larger Listening Areas**

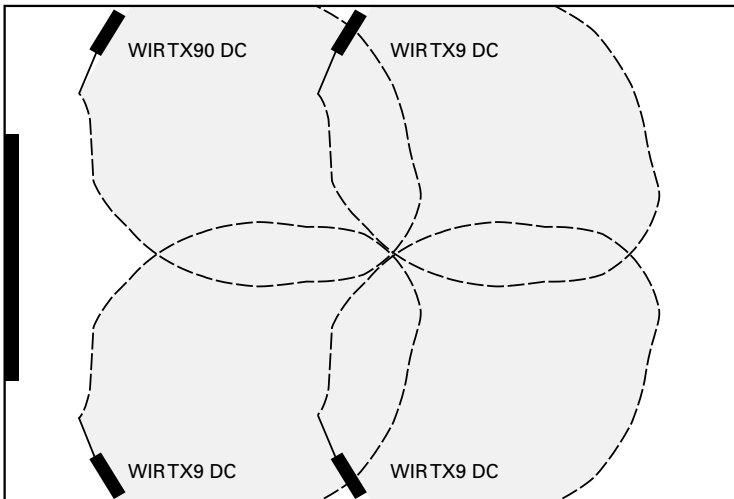

**Overlapping Illumination patterns to cover Larger Listening Areas**

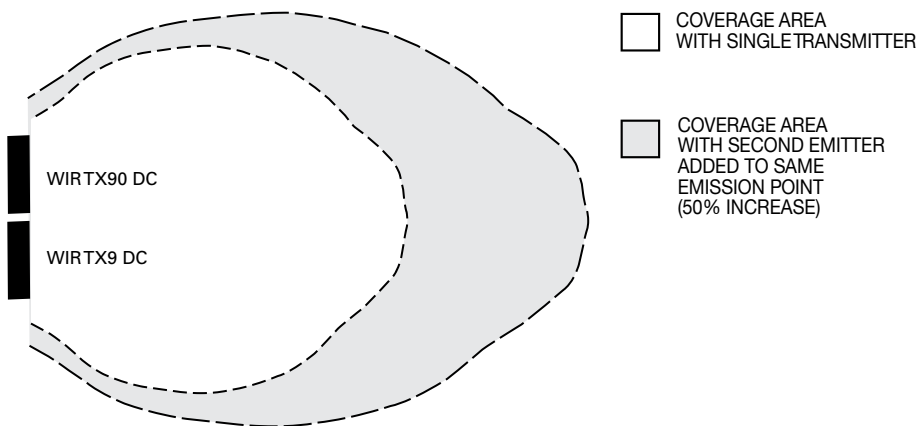

**WIR TX90 Rear View**

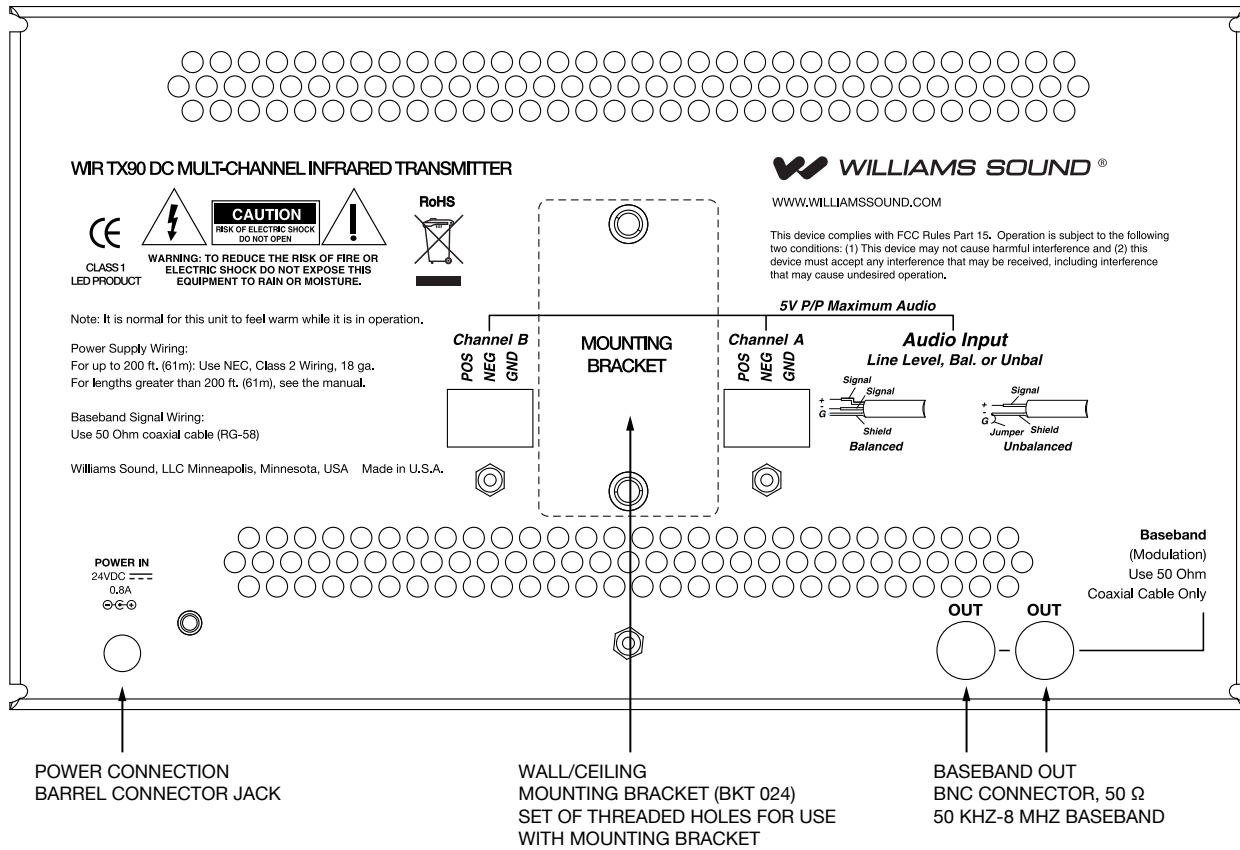

**Connect Power**



**WARNING: POWERLINE VOLTAGE MUST NOT FALL BELOW 90V, OR SYSTEM PERFORMANCE WILL BE GREATLY REDUCED!**

**Power Connection (Universal)**

Connect the TFP 053 power supply to the barrel connector jack located on the rear of the TX90 DC (see “WIR TX90 Rear View”). Use the line cord appropriate for the country of use.

**WLC 004** USA Line Cord

**WLC 005** Euro Line Cord

**WLC 006** UK Line Cord

**WLC 007** Australia Line Cord

**WCA 123** DC Power Extension Cable. This optional cable can be used to extend the DC power connection by 50 ft.

**NOTE:** The WIR TX90 DC transmits when a baseband signal is present, and will shut off after 20 minutes when no baseband signal is present. This auto shut-off feature preserves the life of the infrared LEDs and reduces power consumption.

This system is designed for class 2, low-voltage wiring. Always follow local electrical codes when doing low voltage wiring.

## Connect Audio Source

Determine the length of the audio cable needed to connect to the sound system to the WIR TX90 DC transmitter. Install the supplied Phoenix connector on the end of the audio cable to be connected to the transmitter. See the back of the WIR TX90 DC for wiring instructions.

### Audio Source Connections

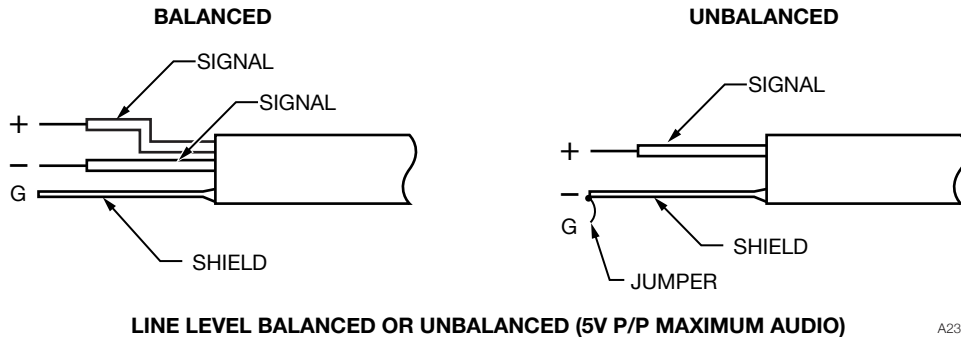

The WIR TX90 DC will accept line level, balanced or unbalanced audio inputs. If you wish to operate in single channel mode, plug the audio cable with the installed Phoenix connector in “Channel A” OR the “Channel B” connector. If you choose to operate in two channel mode, plug the audio cables with Phoenix connectors in both “Channel A” AND “Channel B” connector.

**NOTE:** By default, the WIR TX90 DC is set to operate in two-channel mode. To turn Channel A or Channel B on/off, refer to the instructions Selecting a Channel, below.

### Bottom of WIR TX90 DC

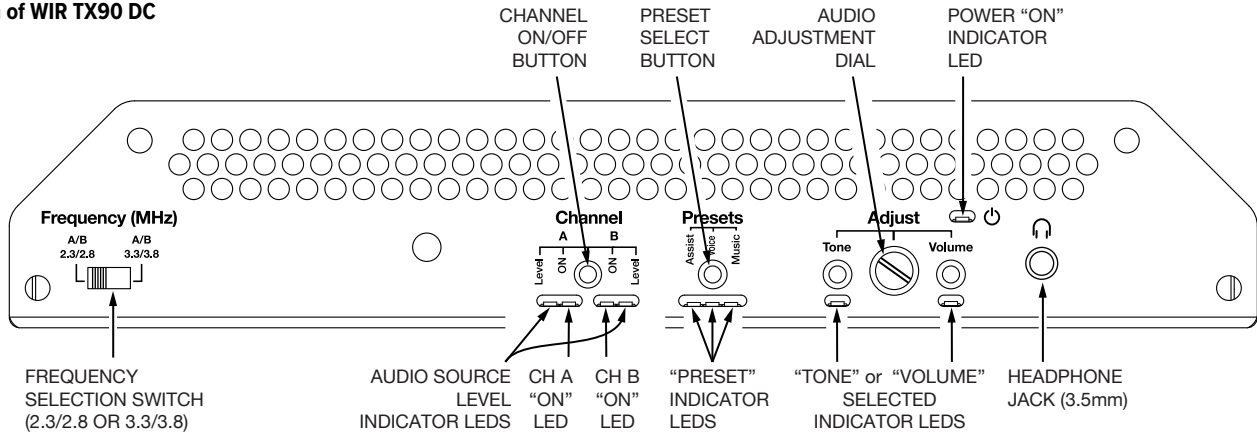

## Selecting a Carrier Frequency

The WIR TX90 DC offers two sets of carrier frequencies for Channel A and Channel B: 2.3 and 2.8 MHz or 3.3 and 3.8 MHz.

The WIR TX90 DC is preset to 2.3 and 2.8 MHz, which are the most commonly used. Move the slide switch to select a pair of operating frequencies.

## Selecting a Channel

To activate a channel, press the “CHANNEL” button until the channel “ON” indicator lights. For example, to operate only channel A, press the “CHANNEL” button until only the channel A “ON” indicator lights. To operate both channel A and B, press the “CHANNEL” button until both “ON” indicators light.

**Note:** If you’re only using one channel, make sure the other channel is turned off to maximize system coverage.

## Select the Audio Processing Application Preset

---

The WIR TX90 DC offers three preset audio processing options for the most common applications: Music, Voice, and Hearing Assist. Use the “Music” setting when maximum dynamic range and audio quality are preferred. Use the “Voice” setting for simultaneous interpretation, audio description, or other applications with users that have primarily normal hearing. Use the “Assist” setting for hearing assistance applications to meet the reduced dynamic range needs of hearing impaired listeners. You may select the same audio pre-set for both Channel A and Channel B, or you may select them independently.

To select the audio processing preset, you must first activate the channel you want to adjust. Press the “channel” button to activate the channel(s) you want to choose an audio processing preset for, then press the “Presets” button to choose the preset. The Music, Voice, or Assist indicator will light to show your selection. After 10 seconds, the setting will be stored.

## Adjusting Audio Input Level

---

The TX90 DC is designed to accept a line-level audio input signal. The “Level” indicator light for each channel is used to help adjust the audio input level. When the indicator does not light, the input signal level is too low. When the indicator is flashing, the signal level is optimal. When the indicator is steadily lit, but does not flash, the input level is too high and can cause distortion. You can adjust the input level of both channels simultaneously, or independently.

Make sure the input audio signal is connected to the WIR TX90 DC. To adjust the audio input level, first activate the channel(s) you want to adjust by pressing the “CHANNEL” button, then press the “VOLUME” button. The Volume indicator will light. Now, turn the “ADJUST” knob clockwise to increase the input signal or counter-clockwise to decrease the input signal until the channel “Level” indicator is flashing. After 10 seconds, the setting will be stored.

---

### IMPORTANT

Audio level NORMAL (optimal): the audio indicator level will **flash at a 1 second rate**.

Audio level too HIGH: the audio indicator level will **stay on** or **flash erratically**.

Audio level too LOW: the audio indicator level will be **off**.

---

## Adjusting Tone

---

The WIR TX90 DC has a tone adjustment to suit user preference and to compensate for the different frequency responses of various infrared receiver models. First, make sure the audio source is active. Use a receiver from the system to listen to the signal as you adjust the tone control.

To adjust the tone, first activate the channel(s) you want to adjust by pressing the “CHANNEL” button, then press the “TONE” button. The tone indicator will light. Now turn the “ADJUST” knob clockwise to emphasize high frequencies (best for hearing assistance use). When you have reached the maximum adjustment, there will be no further change in tone. Turn the “ADJUST” knob counter-clockwise to decrease the high frequency emphasis. When you have reached the minimum adjustment, there will be no further change in tone. After 10 seconds, the setting will be stored.



# Using the Optional WIR TX9 DC Slave Emitter for Additional Coverage

For larger facilities, additional emitter panels can be used to increase the overall coverage area. In these cases, we recommend using the WIR TX9 DC slave emitter in tandem with the WIR TX90 DC. The WIR TX90 DC can drive multiple WIR TX9 DC emitters at one time. Each TX9 DC emitter will require its own power supply.

## Connecting a WIR TX9 Emitter to a WIR TX90 Transmitter

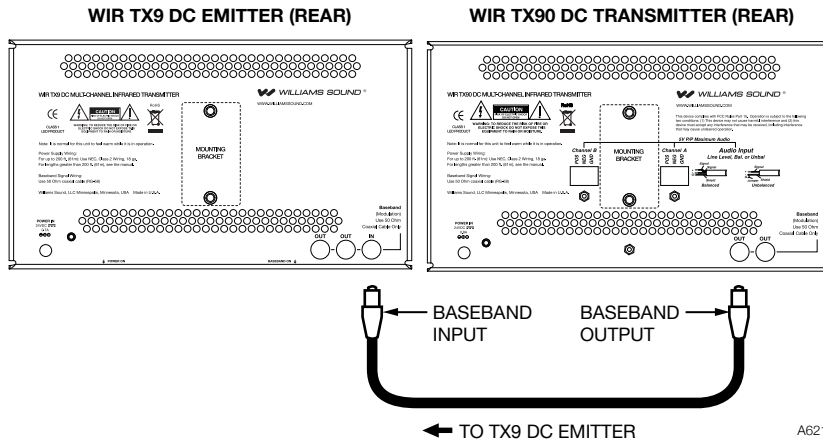

To add a second WIR TX9 DC emitter panel to the WIR TX90 DC transmitter, repeat the process above (the WIR TX90 DC transmitter has two baseband output jacks).

**Note:** The WIR TX9 DC emitter panels can be “chained” together if needed for unlimited coverage area. Each WIR TX9 DC emitter will require its own power supply.

## Chaining multiple WIR TX9 DC Emitters Together

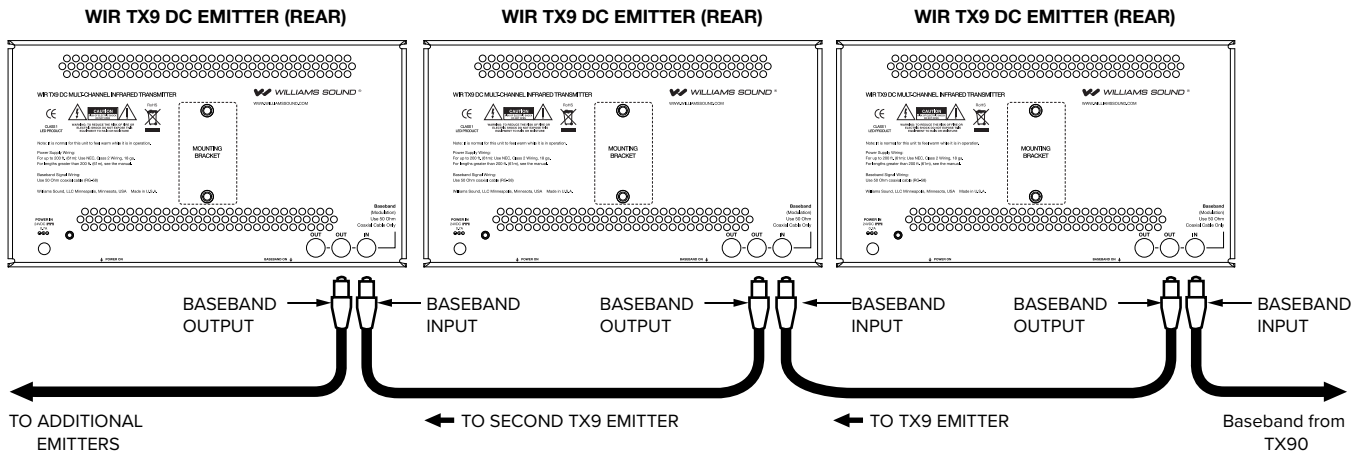

## Receiver Safety Information

---

### HEARING SAFETY

#### CAUTION!

Williams AV receivers are designed to amplify sounds to a high volume level which could potentially cause hearing damage if used improperly. **To protect your hearing and the hearing of others:**

1. Make sure the volume is turned down before putting on the earphone or headphone before adjusting the volume to a comfortable level.
2. Set the volume level at the minimum setting that you need to hear.
3. If you experience feedback (a squealing or howling sound), reduce the volume setting and move the microphone away from the earphone or headphone.
4. Do not allow children **or other unauthorized persons** to have access to the receiver.

### BATTERY SAFETY AND DISPOSAL

#### CAUTION!

Williams AV receivers are supplied with disposable Alkaline batteries. Do not attempt to recharge alkaline batteries, which may explode, release dangerous chemicals, cause burns, or other serious harm to the user or product.

### PACEMAKER SAFETY

#### CAUTION!

1. Before using Williams AV receivers with a pacemaker or other medical device, consult your physician or the manufacturer of your pacemaker or other medical device.
2. If you have a pacemaker or other medical device, make sure that you are using the Williams AV receiver in accordance with safety guidelines established by your physician or the pacemaker manufacturer.

## Recycling Instructions

---

Help Williams AV protect the environment! Please take the time to dispose of your equipment properly.



#### **Product Recycling Instructions:**

Please do NOT dispose of your Williams AV equipment in the household trash. Please take the equipment to an electronics recycling center; OR, return the product to the factory for proper disposal.



#### **Battery Recycling Instructions:**

Please do NOT dispose of used batteries in the household trash. Please take the batteries to a retail or community collection point for recycling.

## Optional Infrared Receivers

### Model WIR RX22-4, Four Channel Receiver

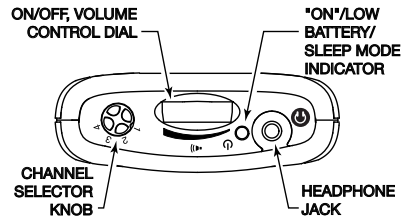

Channel	Frequency
1	2.3 MHz
2	2.8 MHz
3	3.3 MHz
4	3.8 MHz

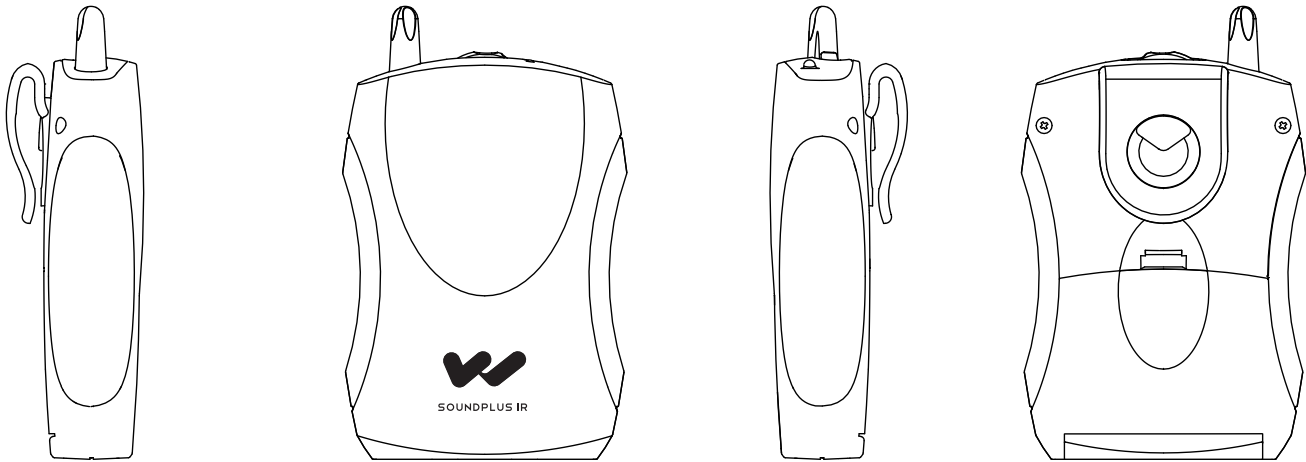

### Model WIR RX18, Two Channel, Under-the-chin Receiver

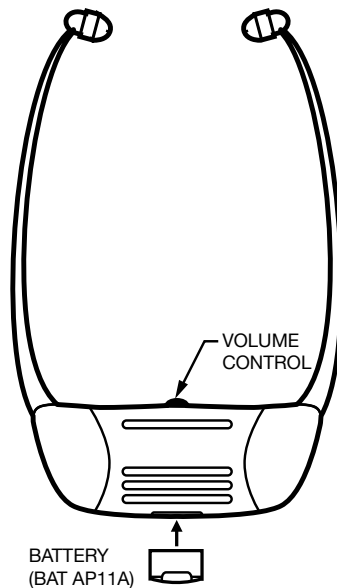

## Optional Chargers

### Multiple Battery Charger, Model CHG 518

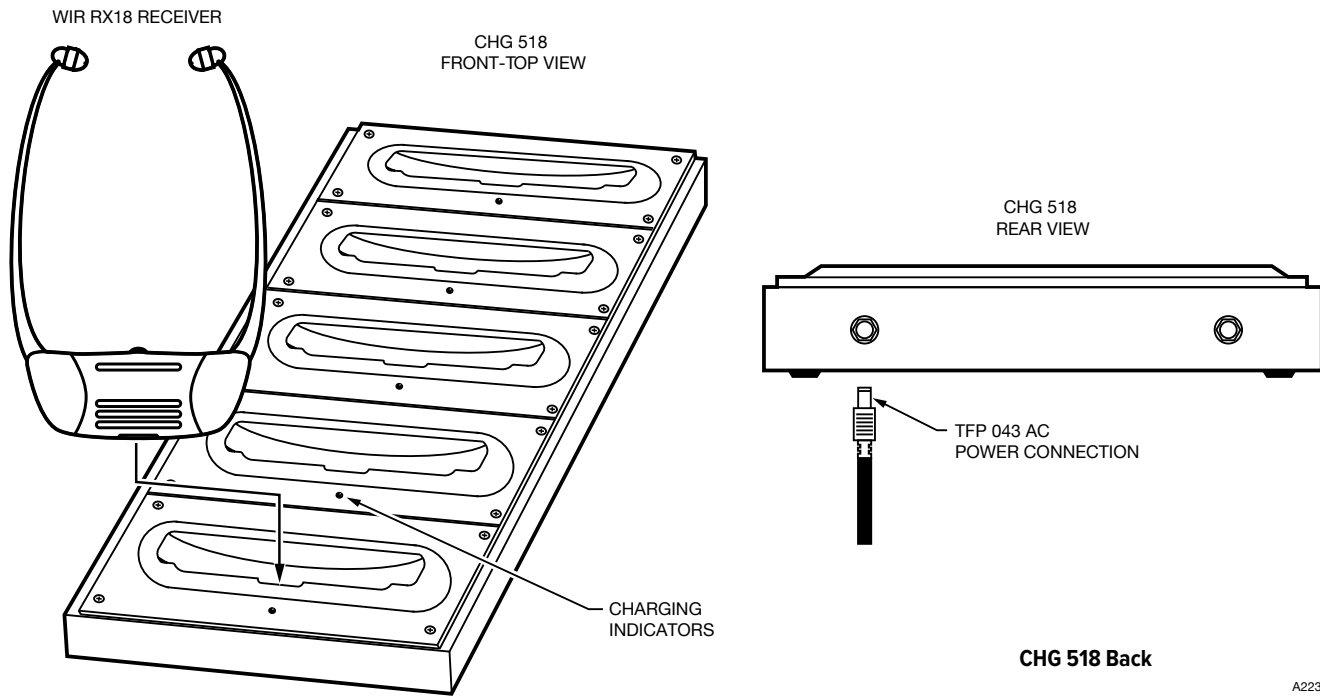

A223

Figure 16: Multiple Battery Charger, Model CHG 3512

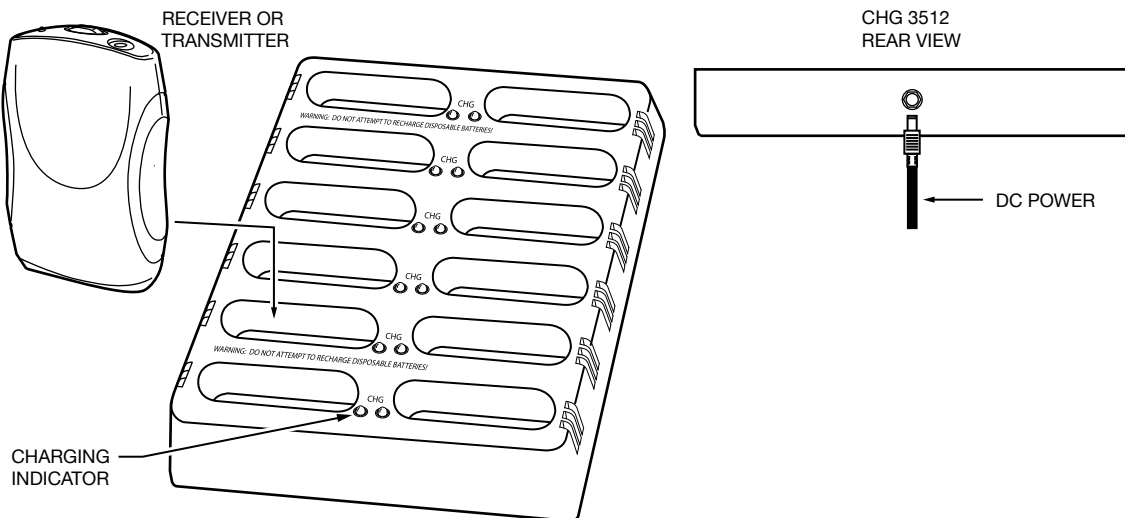

## Troubleshooting

---

### **The WIR TX90 DC “Power On” indicator is not lit.**

- Make sure the power supply is plugged into the transmitter and any remote power switch is on.
- Make sure the electrical outlet is on.
- Make sure the power supply is working (LED is lit).

### **The WIR TX90 DC channel A or B “On” indicator is not lit.**

- Make sure the desired audio channel has been activated. See Selecting a Channel on page 7.
- Make sure the WIR TX90 DC is plugged in.
- Make sure the audio input is connected properly. See page 6 or instructions on the back of the WIR TX90 DC.
- Make sure an active audio signal is being sent to the WIR TX90 DC transmitter.

### **No sound through receivers.**

- Check to make sure the receiver is operating on the same frequency as the transmitter.
- If some of the receivers work but others don't, check for bad batteries or earphones on the receivers that aren't working.
- If none of the receivers work, check to see if the power and audio input cable are connected to the transmitter and that the WIR TX90 DC “Power On” and Channel A or B “On” indicator is illuminated.
- Check to see if the transmitter is connected properly to the sound system. The audio level indicators should flash on channels that are selected.
- Make sure the “eye” is not covered up on the receiver. There must be clear line of sight between the receiver eye and the transmitter panel.

### **Sound through the receivers is weak and noisy.**

- Listen to the audio signal through the headphone jack on the WIR TX90 DC transmitter. If the signal is weak and noisy here, try increasing the audio input level (see Adjust Audio Input Level, page 8), or increase the input signal level from the sound system by turning up the mixer control. If the signal sounds okay, you may need to reposition the transmitter panel or add additional IR emitters to the WIR TX90 DC system.

### **Buzzing or humming noise in sound system.**

- Check for ground loops or noise on the input signal. Call your Authorized Williams AV dealer or representative.

## Specifications - WIR TX90 DC

<b>Dimensions, Weight:</b>	11.25" W x 6.25" H x 2.125" D (28.6 cm x 15.9 cm x 5.4 cm), 1.8 lbs (0.8 kg)
<b>Color:</b>	Black with white legends, black acrylic lens (optional white enclosure available)
<b>Power Supply:</b>	Desktop-style, universal power supply. Input: 100-240 VAC, 50/60 Hz, 0.6 A. Line cord specified by country of use. Output: 24 VDC, 1.0 A, 25 W. Barrel connector. 50 ft DC power supply extension cable available (WCA 123).
<b>Modulation:</b>	FM Wideband, +50 kHz deviation max., 50 uS pre-emphasis
<b>Carrier Frequency:</b>	Channel A: Selectable, 2.3/3.3 MHz, Channel B: Selectable, 2.8/3.8 MHz
<b>Emitter IR Power:</b>	3.5 W
<b>Coverage Area:</b>	30,000 sq. ft. (2,787 sq. m) in single channel mode when using the RX22-4 Receiver 19,000 sq. ft (1,765 sq. m) in two channel mode when using the RX22-4 Receiver 11,000 sq. ft (1,022 sq. m) in four channel mode when using the RX22-4 Receiver 3,350 sq. ft (311 sq. m) in single channel mode when using the RX18 Receiver
<b>Signal-to-Noise Ratio:</b>	>75 dB, +3 dB
<b>Frequency Response:</b>	80 to 15,000 Hz, electrical response
<b>Total Harmonic Distortion:</b>	Less than 0.2%, electrical response at 1 kHz
<b>Compression:</b>	Music preset 1:1, Voice preset 1.5:1, Hearing Assist preset 2:1
<b>Auto Carrier Shut-Off:</b>	20 minute timer shuts off carrier when no audio is present
<b>Power Indicator:</b>	Red LED
<b>Audio Volume Level Controls:</b>	CH A and CH B Input Level, press to select, 28 dB adjustable range
<b>Audio Indicators:</b>	CH A and CH B Audio Level, yellow LED, flash
<b>Carrier LEDs:</b>	2 green LED carrier "on" indicators
<b>Phones Output:</b>	3.5mm TRS headphone jack. CH A tip, CH B ring on jack, 32 ohm headphone (min)
<b>Application Preset:</b>	Music, Voice, Hearing Assist. Frequency response; Music: Flat; Voice: Mid-range boost; Hearing Assist: High frequency boost
<b>Tone Control:</b>	Press to select, 21 dB adjustable range (1 kHz between low boost/hi-cut and low cut/hi boost).
<b>Power Input:</b>	24 VDC, 0.8 A, 25 W
<b>Audio Input Connector:</b>	CH A and CH B, 3 wire Phoenix
<b>Input Level:</b>	Balanced or unbalanced, 316 mVRMS (-10 dBV) nominal, 5.7 k $\Omega$ input impedance; max input (over volume range) -21 to +7 dBV.
<b>Baseband Output:</b>	BNC, 50 $\Omega$ , for use with TX9 or TX9 DC only
<b>Baseband Cable:</b>	RG 58 Coax, BNC connectors, maximum 1000 ft. (300 m) length
<b>Operating Requirements:</b>	0-50° C (+32 °F to 122 °F) ambient temperature, non-condensing, non-corrosive atmosphere
<b>Mounting Kits:</b>	Wall or Ceiling Mount: BKT 024 Omnidirectional mount. Optional: Tripod Stands SS-6.
<b>Warranty:</b>	5 years on transmitter (90 days on accessories)
<b>Approvals</b>	CE, FCC, RoHS, WEEE
<b>Compatible Receivers:</b>	WIR RX22-4 Four-Channel Receiver WIR RX18 Two-Channel Receiver
<b>Notes</b>	Specifications: Single end input, volume & tone controls at mid point, 1 kHz, "Music" Preset

**NOTE:** Specifications subject to change without notice.

Visit our website for the latest specifications and publications: [www.williamsav.com](http://www.williamsav.com)

## Specifications - WIR TX9 DC

<b>Dimensions, Weight:</b>	11.25" W x 6.25" H x 2.125" D (28.6 cm x 15.9 cm x 5.4 cm), 1.8 lbs (0.8 kg)
<b>Color:</b>	Black with white legends, black acrylic lens (optional white enclosure available)
<b>Power Supply:</b>	Desktop-style, universal power supply. Input: 100-240 VAC, 50/60 Hz, 0.6A. Line cord specified by country of use. Output: 24 VDC, 1.0 A, 25W. Barrel connector. 50 ft DC power supply extension cable available (WCA 123).
<b>Carrier Frequency:</b>	Accommodates baseband sub carriers from 2.3-3.8 MHz
<b>Emitter IR Power:</b>	3.5 watts
<b>Coverage Area:</b>	30,000 sq. ft. (2,787 sq. m) in single channel mode when using the RX22-4 Receiver 19,000 sq. ft (1,765 sq. m) in two channel mode when using the RX22-4 Receiver 11,000 sq. ft (1,022 sq. m) in four channel mode when using the RX22-4 Receiver 3,350 sq. ft (311 sq. m) in single channel mode when using the RX18 Receiver
<b>Baseband Indicator:</b>	Red LED
<b>Power Indicator:</b>	Red LED
<b>Auto Carrier Shut-Off:</b>	Turns off LEDs when no baseband is present
<b>Power Input:</b>	24 VDC, 0.8 A
<b>Baseband Input:</b>	BNC, 50 Ω, for use with MOD 232, TX 90, TX 90 DC, TX 9 and TX 9 DC
<b>Baseband Output:</b>	BNC, 50 Ω, for use with TX 9 or TX 9 DC only
<b>Baseband Cable:</b>	RG 58 Coax, BNC Connectors, maximum 1000 ft (300 m) length.
<b>Operating Requirements:</b>	32-122 °F (0-50 °C), ambient temperature, non-condensing, non-corrosive atmosphere
<b>Mounting Kits:</b>	Wall or Ceiling Mount: BKT 024 Omnidirectional mount; Optional: Tripod Stands: SS-11 or SS-6
<b>Warranty:</b>	5 years on transmitter (90 days on accessories)
<b>Approvals:</b>	CE, FCC, RoHS, WEEE
<b>Compatible Receivers:</b>	WIR RX22-4 Four-Channel Receiver WIR RX18 Two-Channel Receiver
<b>Notes:</b>	<b>Specifications: Single end input, volume &amp; tone controls at mid point, 1 kHz, "Music" Preset</b>

## Limited Warranty

Williams AV products are engineered, designed, and manufactured under carefully controlled conditions to provide you with many years of reliable service. Williams AV warrants the Sound Plus™ Infrared Listening System against defects in materials and workmanship for FIVE (5) years. During the first five years from the purchase date, we will promptly repair or replace the Sound Plus™ Infrared Listening System.

*Microphones, earphones, headphones, batteries, chargers, cables, carry cases, and all other accessory products carry a 90-day warranty.*

Williams AV HAS NO CONTROL OVER THE CONDITIONS UNDER WHICH THIS PRODUCT IS USED. Williams AV, THEREFORE, DISCLAIMS ALL WARRANTIES NOT SET FORTH ABOVE, BOTH EXPRESS AND IMPLIED, WITH RESPECT TO THE SOUND PLUS™ INFRARED LISTENING SYSTEM, INCLUDING BUT NOT LIMITED TO, ANY IMPLIED WARRANTY OF MERCHANTABILITY OR FITNESS FOR A PARTICULAR PURPOSE. Williams AV SHALL NOT BE LIABLE TO ANY PERSON OR ENTITY FOR ANY MEDICAL EXPENSES OR ANY DIRECT, INCIDENTAL OR CONSEQUENTIAL DAMAGES CAUSED BY ANY USE, DEFECT, FAILURE OR MALFUNCTIONING OF THE PRODUCT, WHETHER A CLAIM FOR SUCH DAMAGES IS BASED UPON WARRANTY, CONTRACT, TORT OR OTHERWISE, THE SOLE REMEDY FOR ANY DEFECT, FAILURE OR MALFUNCTION OF THE PRODUCTS REPLACEMENT OF THE PRODUCT. NO PERSON HAS ANY AUTHORITY TO BIND Williams AV TO ANY REPRESENTATION OR WARRANTY WITH RESPECT TO THE SOUND PLUS™ INFRARED LISTENING SYSTEM. UNAUTHORIZED REPAIRS OR MODIFICATIONS WILL VOID THE WARRANTY.

The exclusions and limitations set out above are not intended to, and should not be construed so as to contravene mandatory provisions of applicable law. If any part or term of this Disclaimer of Warranty is held to be illegal, unenforceable, or in conflict with applicable law by a court of competent jurisdiction, the validity of the remaining portions of this Disclaimer of Warranty shall not be affected, and all rights and obligations shall be construed and enforced as if this Limited Warranty did not contain the particular part or term held to be invalid.

If you experience difficulty with your system, call Toll-Free for customer Assistance: **1-800-843-3544 (U.S.A.) or +1 952 943 2252 (Outside the U.S.A.)** Your warranty becomes effective the date you purchase your system. Your returned warranty card is our way of knowing when your warranty begins. It also gives us important information about your system including the serial number. This information will help us serve you better in the future. Please take a moment to complete and mail the attached card. Thank you.

**WILLIAMS AV**

info@williamsav.com / www.williamsav.com  
800-843-3544 / INTL: +1-952-943-2252